

REVISION RECORD				
REV	ECO	DESCRIPTION	DRFT	CHKD

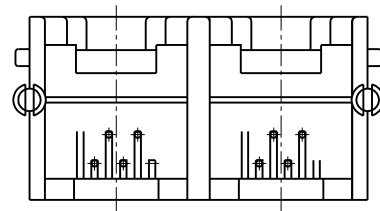
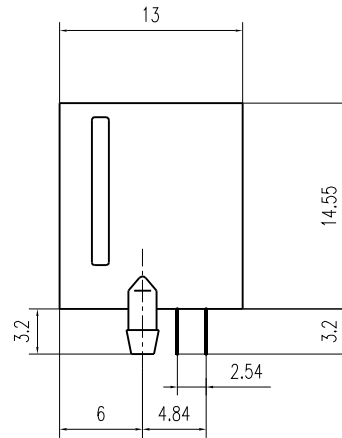
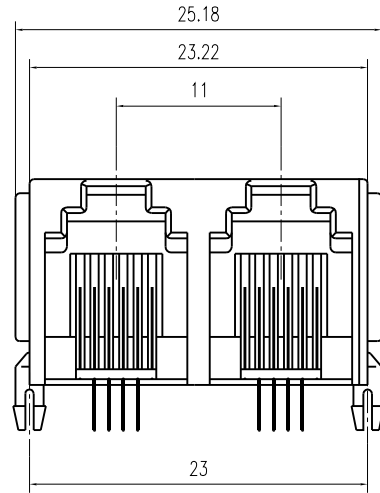

NOTES:

ELECTRICAL:

- 1. VOLTAGE RATING :125 VAC RMS.
- 2. CURRENT RATING :1.5 AMP.
- 3. CONTACT RESISTANCE :30 MILLIOHMS MAX.
- 4. INSULATION RESISTANCE :500 MEGOHMS MIN @ 500V DC .
- 5. DIELECTRIC STRENGTH :1000V AC RMS 50Hz. 1MIN.

MECHANICAL:

- 1. HOUSING MATERIAL :GLASS FILLED POLYESTER UL94V-0.
- 2. CONTACT MATERIAL :PHOSPHOR BRONZE ϕ 0.46mm.
- 3. PLATING :GOLD PLATING OVER NICKEL.
- 4. OPERATING :750 CYCLES MIN.
- 5. PCB RETENTION PRE-SOLDER :1 LB MIN.

ENVIRONMENTAL:

- 1. Temperature Range : -45°C~+85°C
- 2. Relative Humidity : 90~95% (40 \pm 2°C)

PCB LAYOUT

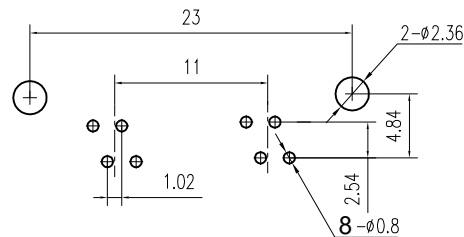

DETACHED LISTS	mm (inch)		DFTO:	DATE:	Coorle Technology			
	Tolerance Exept as Noted		CHKD:	DATE:				
	mm		MFO:	DATE:				
	0 \pm 0.2		APPVL:	DATE:				
	00 \pm 0.15		MATERIAL:		5521 1*2 6P4C			
	000 \pm 0.075		Q`TY:				DRAWING NO.	SIZE
	ANGLES \pm 0.5		FINISH:		/PART NO.		A4	06/06/02
			SCALE: 2:1		DO NOT SCALE DRAWING		SHEET	OF